

**Programmes After Market Services
NSB-5 Series Transceivers**

CARK 64 / 91 Installation Guides

Contents

	Page No
CARK-64	5
Introduction	5
Unpacking	6
Component Parts	7
Installation and Testing	7
CARK-91	8
Introduction	8
Unpacking	9
Component Parts	10
Installation	11
Testing	13

CARK-64

Introduction

This installation guide has been prepared to provide the basic information necessary to install this car kit. This guide is not intended to be definitive, because different types and models of vehicles will require different installation work. The information given is for general guidance only.

The terms of warranty demand that this car kit be installed by an experienced installer and only genuine Nokia parts are used. An end user should never attempt to install this car kit without professional assistance as the installation requires special tools and knowledge.

Please refer to the telephone's User's Guide for instructions on the telephone's operation, care and maintenance, including important safety information. Note: Read the warnings below before beginning the installation procedure.

WARNINGS

- 1 ENSURE THAT THE VEHICLE'S BATTERY IS DISCONNECTED BEFORE **YOU START THE INSTALLATION PROCEDURE, AND THAT IT REMAINS DISCONNECTED DURING THE PROCEDURE.**
- 2 DO NOT SMOKE OR USE OPEN FLAMES WHEN WORKING NEAR THE **VEHICLE'S FUEL SYSTEM.**
- 3 ENSURE THAT THE VEHICLE'S ELECTRICAL CABLES, HYDRAULIC LINES, FUEL LINES, AND SAFETY EQUIPMENT ARE NOT DAMAGED DURING INSTALLATION.
- 4 ENSURE THAT NORMAL CONTROL AND OPERATION OF THE VEHICLE IS NOT IMPAIRED BY THE INSTALLATION, PARTICULARLY THE BRAKES AND STEERING. ENSURE THAT AIRBAG OPERATION IS NOT OBSTRUCTED.
- 5 ELECTRONIC AND OTHER SOPHISTICATED SYSTEMS (e.g. SPEED CONTROL, ABS ANTI-LOCK BRAKE, FUEL INJECTION, NAVIGATION, AND AIRBAG SYSTEMS) ARE RELATIVELY IMMUNE TO MALFUNCTION CAUSED BY NEARBY RADIO TRANSMISSIONS. HOWEVER, SHOULD YOU EXPERIENCE FALSE OPERATION OF THESE SYSTEMS OR ARE IN ANY DOUBT WHATSOEVER AS TO THEIR FUNCTIONALITY, PLEASE CONSULT THE VEHICLE'S DEALER.
- 6 THE CAR KIT IS SUITABLE FOR USE ONLY IN VEHICLES WITH AN 11..32 V NEGATIVE GROUNDING. USE ON OTHER SUPPLY VOLTAGES OR ALTERNATIVE POLARITY WILL DAMAGE THE EQUIPMENT.
- 7 THE PHONE SHOULD NOT BE LEFT SWITCHED ON FOR EXTENDED PERIODS WITHOUT RUNNING THE VEHICLE'S ENGINE. FAILURE TO COMPLY COULD DRAIN THE VEHICLE'S BATTERY.

Unpacking

Carefully unpack the equipment and ensure that the following items are present:

Phone Holder	MBC-1
Swivel Mount	HHS-9
Mobile Charger	LCH-9

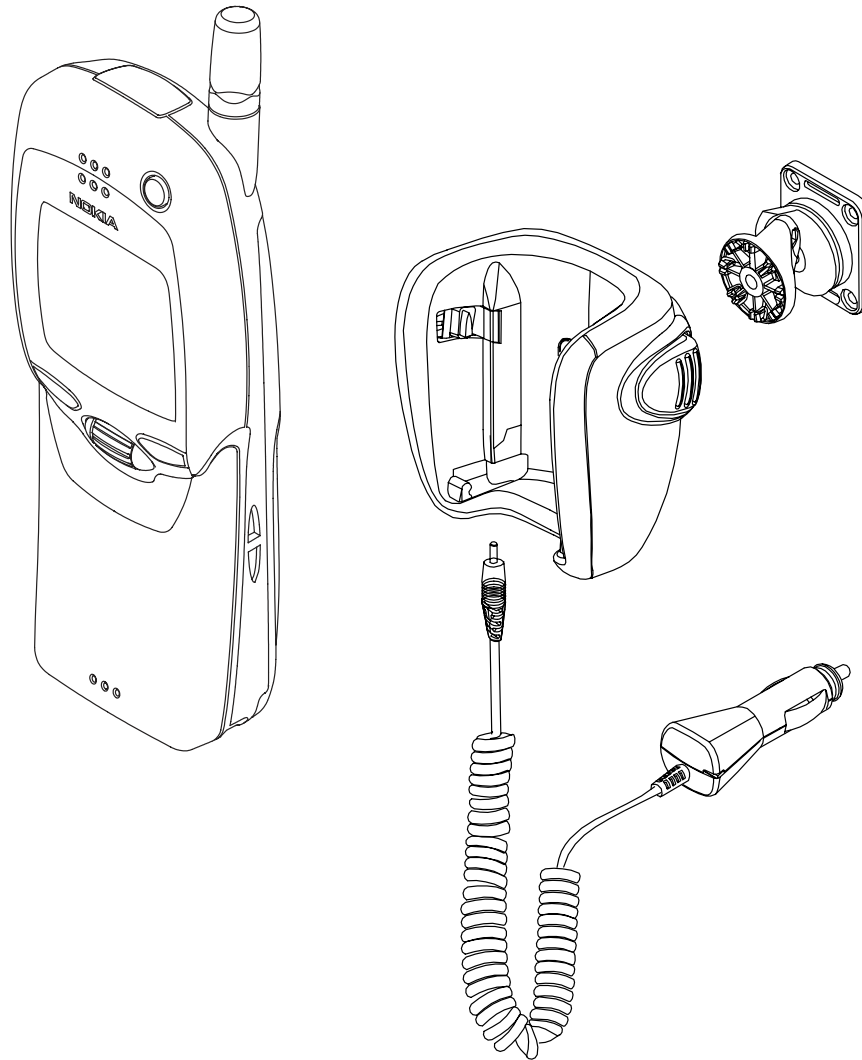

Component Parts

Phone Holder MBC-1

The holder allows the phone to be firmly located in a convenient position. The holder is attached to the vehicle's interior using the swivel mount HHS-9, or the mounting plate MKU-1. The mounting must be secured with a screw (included with HHS-9). The screw recess can then be covered with the NOKIA logo plate.

Mounting Plate MKU-1 and Swivel Mount HHS-9

MKU-1 is a fixed position mounting plate; HHS-9 is a swivel mount which allows for adjustable fixing. The two mounting plates are interchangeable.

Mobile Charger LCH-9

The mobile charger enables the phone to be charged via the vehicle's cigarette lighter socket. The charger connects to the phone via a d.c. jack socket located on the base of phone. The supply voltage may vary between 11 and 32 V.

Installation and Testing

There are some important aspects that require special attention when positioning the phone holder.

The positioning of the phone holder is the most important factor when trying to achieve the most comfortable position for the user. The location of the holder should be selected so that the visibility of the phone's display is good under all lighting conditions, but not so that the driver's attention is easily distracted. The phone holder can be installed so that only one of the release buttons is visible, as only one of the buttons needs to be pressed to release the phone. The holder should be located so that the driver can easily reach the keypad. Under no circumstances should the holder prevent the driver from controlling or operating the vehicle in any way or observing traffic.

Once installed, the equipment should be tested to ensure that it is operating satisfactorily and that the position of the unit does not impair the driver's ability to control and operate the vehicle in any way.

Use the phone to make a call when the vehicle is parked with the engine running. During the call, switch off the engine. Ensure that the phone is operational both with the engine running, and with the engine switched off.

For operating information refer to the User's Guide supplied with the phone.

CARK-91

Introduction

This installation guide has been prepared to provide the basic information necessary to install this car kit. This guide is not intended to be definitive, because different types and models of vehicles will require different installation work. The information given is for general guidance only.

The terms of warranty demand that this car kit be installed by an experienced installer and only genuine Nokia parts are used. An end user should never attempt to install this car kit without professional assistance as the installation requires special tools and knowledge.

Please refer to the telephone's User's Guide for instructions on the telephone's operation, care and maintenance, including important safety information. Note: Read the warnings below before beginning the installation procedure.

WARNINGS

- 1 ENSURE THAT THE VEHICLE'S BATTERY IS DISCONNECTED BEFORE YOU START THE INSTALLATION PROCEDURE, AND THAT IT REMAINS DISCONNECTED DURING THE PROCEDURE.
- 2 DO NOT SMOKE OR USE OPEN FLAMES WHEN WORKING NEAR THE VEHICLE'S FUEL SYSTEM.
- 3 ENSURE THAT THE VEHICLE'S ELECTRICAL CABLES, HYDRAULIC LINES, FUEL LINES, AND SAFETY EQUIPMENT ARE NOT DAMAGED DURING INSTALLATION.
- 4 ENSURE THAT NORMAL CONTROL AND OPERATION OF THE VEHICLE IS NOT IMPAIRED BY THE INSTALLATION, PARTICULARLY THE BRAKES AND STEERING. ENSURE THAT AIRBAG OPERATION IS NOT OBSTRUCTED.
- 5 ELECTRONIC AND OTHER SOPHISTICATED SYSTEMS (e.g. SPEED CONTROL, ABS ANTI-LOCK BRAKE, FUEL INJECTION, NAVIGATION, AND AIR-BAG SYSTEMS) ARE RELATIVELY IMMUNE TO MALFUNCTION CAUSED BY NEARBY RADIO TRANSMISSIONS. HOWEVER, SHOULD YOU EXPERIENCE FALSE OPERATION OF THESE SYSTEMS OR ARE IN ANY DOUBT WHATSOEVER AS TO THEIR FUNCTIONALITY, PLEASE CONSULT THE VEHICLE'S DEALER.
- 6 THE CAR KIT IS SUITABLE FOR USE ONLY IN VEHICLES WITH A 12 V NEGATIVE GROUNDING. USE ON OTHER SUPPLY VOLTAGES OR ALTERNATIVE POLARITY WILL DAMAGE THE EQUIPMENT.
- 7 THE PHONE SHOULD NOT BE LEFT SWITCHED ON FOR EXTENDED PERIODS WITHOUT RUNNING THE VEHICLE'S ENGINE. FAILURE TO COMPLY COULD DRAIN THE VEHICLE'S BATTERY.

Unpacking

Carefully unpack the equipment and ensure that the following items are present.

Advanced Active Car Holder	MCC-1
Advanced HF Unit	HFU-2
Power Cable	PCH-4J
Mounting Plate	MKU-1
Swivel Mount	HHS-9
HF Microphone	HFM-8

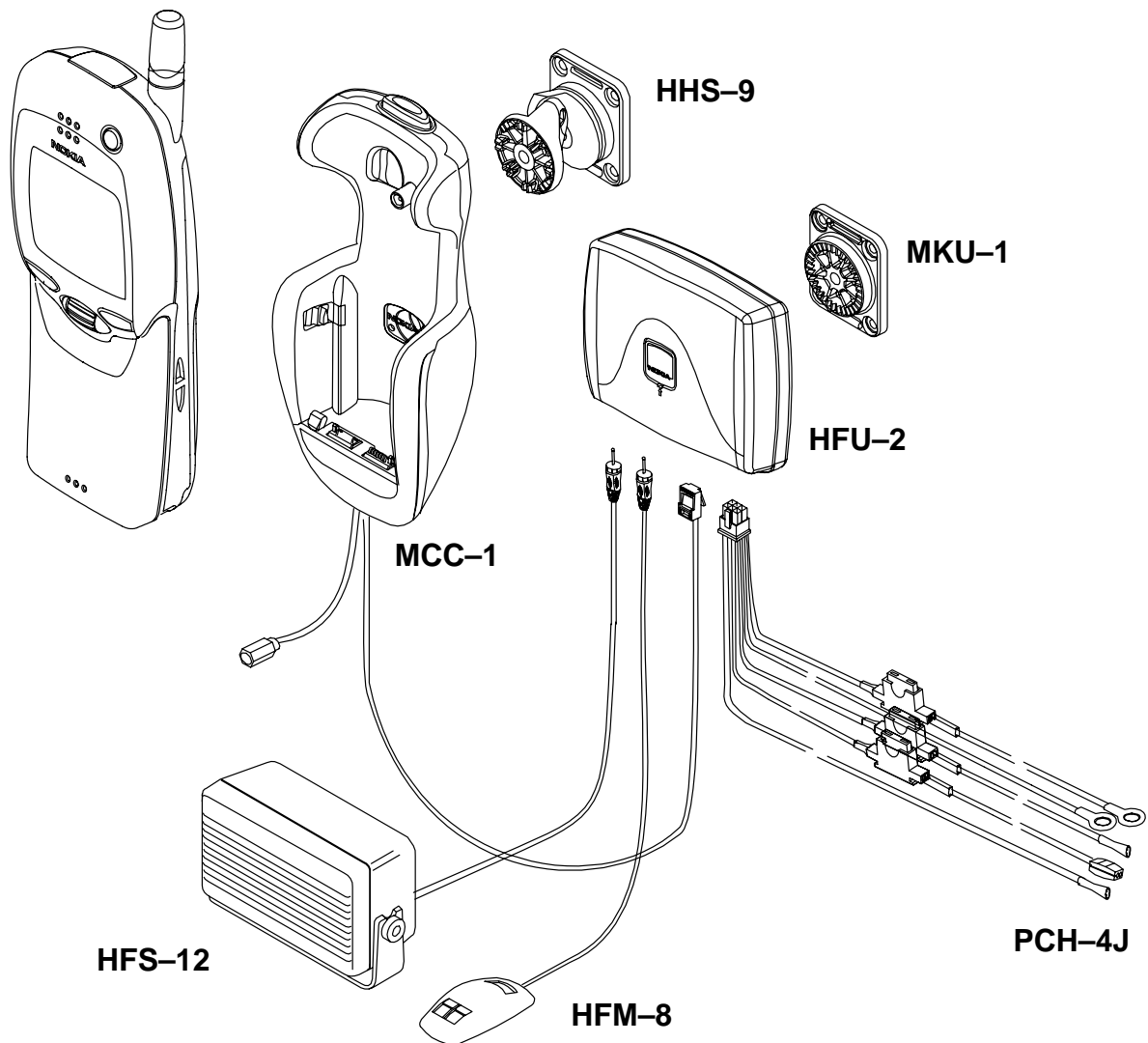

Component Parts

Advanced Active Holder MCC-1

The holder allows the phone to be firmly located in a convenient position. The holder is attached to the vehicle's interior using the swivel mount HHS-9. The mounting must be secured with a screw (included with HHS-9). The screw recess can then be covered with the NOKIA logo plate.

Advanced HF Unit HFU-2

The handsfree unit enables the phone to operate in handsfree mode. The unit is attached to the vehicle interior using the mounting plate MKU-1. The mounting must be secured with a screw (included with MKU-1). A temporary installation can be achieved using installation belts (not supplied).

Power is supplied from the vehicle's battery via the power cable PCH-4J. The handsfree unit provides the power supply to the phone via the system connector.

The HF microphone HFM-8, connects to the mic socket. And the HF speaker HFS-12, connects to the socket.

Mounting Plate MKU-1 and Swivel Mount HHS-9

MKU-1 is a fixed position mounting plate; HHS-9 is a swivel mount which allows for adjustable fixing. The two mounting plates are interchangeable.

HF Microphone HFM-8

The HF microphone connects directly to the handsfree unit (mic socket). Insert the plug into the mic socket and twist 90.... to lock firmly in place.

HF Speaker HFS-12

The HF speaker connects directly to the handsfree unit (socket). Insert the plug into the socket and twist 90.... to lock firmly in place.

Power Cable PCH-4J

The power cable connects the standard handsfree unit HFU-2 to the vehicle's power supply. The red wire must be connected to the + voltage on the vehicle's power supply via the supplied fused connector. The black wire must be attached to a good negative GND connection.

The blue ignition sense (IGNS) wire is connected to +12 V voltage controlled by the vehicle's ignition key via the supplied fused connector. See section "Ignition Sense".

The yellow wire is used for car radio muting (XCRM). The line goes down to 0 volts during a call. See section "Car Radio Muting".

The green wire is used for motor antenna (AMC). The voltage in this output is +12 V whenever the phone is on. See section "Antenna Motor Control".

External Mobile Antenna (not supplied)

The cellular phone is designed to operate with a high quality external antenna. However, due to many different types of antennas being available, an antenna is NOT included as part of this kit. Please, consult the dealer to find out which is the most suitable antenna type for your installation.

Installation

There are some important aspects that require special attention in positioning car kit accessories.

The positioning of the phone holder is the most important factor when trying to achieve the most comfortable position for the user. The location of the holder should be selected so that the visibility of the phone's display is good under all lighting conditions, but not so that the driver's attention is easily distracted. The holder should be located so that the driver can easily reach the keypad. Under no circumstances should the holder prevent the driver from controlling or operating the vehicle in any way or observing traffic.

The HF microphone should be installed according to the directions in the separate microphone installation guide. Ensure the microphone is as close to the driver's mouth as possible, and attached to a surface that is mechanically quiet. The microphone should be mounted at least 3 ft/1 m away from the handsfree unit speaker to avoid acoustic feedback.

Ensure cables are routed as far away as possible from the vehicle's electronic systems (refer to WARNINGS)*. Also, ensure that cables are not subjected to undue mechanical stress e.g. under seats or against sharp edges.

* To prevent disturbance, cables should be routed as far away from the interference source as possible

Ignition Sense IGNS

The ignition sense feature prevents your car kit from draining the car battery by executing an auto power off in 20 seconds after the ignition key has been turned off. The blue wire of the power cable is used for the ignition sense feature. The use of ignition sense is recommended to prevent accidental draining of the car's battery. The wire is connected via a 1 A fuse to a 12/24 volt potential that is controlled by the ignition key. Do not connect it directly to the high voltage sections of the ignition circuit.

Car Radio Muting CRM

The car kit offers a feature that can mute the car radio automatically during a conversation. This feature is convenient and provides for safer handsfree operation. The car radio muting feature is based on a grounded line, so it means that in standby, the yellow wire (XCRM) is not grounded and car radio works normally, but during a call, line is grounded and car radio is muted. Note that an auxiliary relay or muting unit must be used when the car radio doesn't have a mute feature available.

When a relay is used, connect of series with the car radio main supply. A 200 mA fuse

should be used to protect the XCRM output in event of a short circuit. Some radios have separate supplies for amplifiers and motors, and another for memory backup purposes. Very often these radios also have a secret code system, which activates itself if a break in the memory supply is detected. Be careful when installing the relay not to break the memory supply (usually marked ACC or +MEM), but to install the relay in the main supply feed.

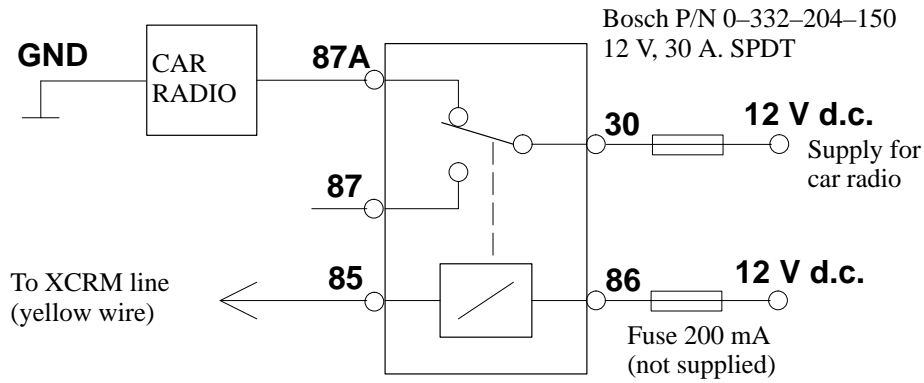

Another possibility is to use a special muting unit, which mutes the radio by connecting load resistors to the speaker lines of the car radio.

Antenna Motor Control AMC

The antenna motor control offers a feature, green wire of the system cable (AMC), that may be used to control different devices on and off. The voltage in this output is +12 V whenever the phone is on. If the phone is turned off, the voltage disappears. The maximum output current is 200 mA, therefore for example motorized antenna must be controlled via a relay, see picture below.

Bosch P/N 0-332-204-150 12 V, 30 A.
SPDT

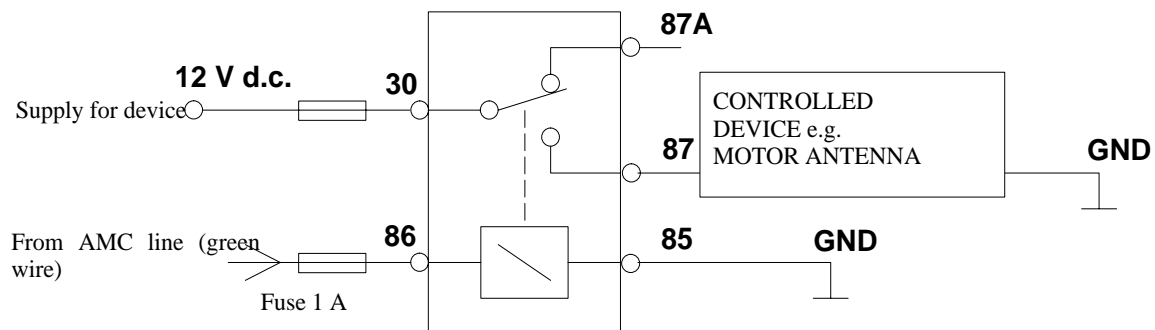

All installations should take into account any special requirements of the customer. However, should the customer require an installation that is illegal or unsafe these facts must be pointed out to the customer and a policy of non-compliance adopted.

Testing

Once installed, the equipment should be tested to ensure that it is operating satisfactorily and that the position of the units does not impair on the driver's ability to control and operate the vehicle in any way.

Use the phone to make a call when the vehicle is parked with the engine running. During the call, switch off the engine. Ensure that the phone is operational with the engine running and with the engine switched off. For operating information refer to the User's Guide supplied with the phone.

